



Date	02/13/2024
Customer	SAMPLE CUSTOMER
Part number	SAMPLE PART
Revision Level	C1
Part name	SAMPLE PART
Inspector	Jim Worth

Dim#	Char#	Nominal	+TOL	-TOL	Part 1	Part 2	Part 3	Comments
1	1	5052-H32 .080"			5052 .078	5052 .079	5053 .079	
2	2	9.000	9.010	8.990	9.005	9.002	9.003	
3	3	3.670	3.700	3.640	3.685	3.690	3.687	
4	4	3.500	3.510	3.490	3.501	3.499	3.502	
5	5	5.000	5.010	4.990	5.006	5.008	5.002	
6	6.1	90	91	89	90.000	90.000	90.000	
6	6.2	90	91	89	90.000	90.000	90.000	
6	6.3	90	91	89	90.000	90.000	90.000	
6	6.4	90	91	89	90.000	90.000	90.000	
7	7	Ø.177	0.197	0.167	0.183	0.183	0.184	
8	8	Ø.332	0.352	0.322	0.341	0.342	0.345	
9	9	100	101	99	100.000	100.000	100.000	
10	10	Ø2.500	2.505	2.495	2.503	2.502	2.503	
11	11	Ø.625	0.630	0.620	0.626	0.625	0.626	

8 7 6 5 4 3 2 1

D
C
B
A

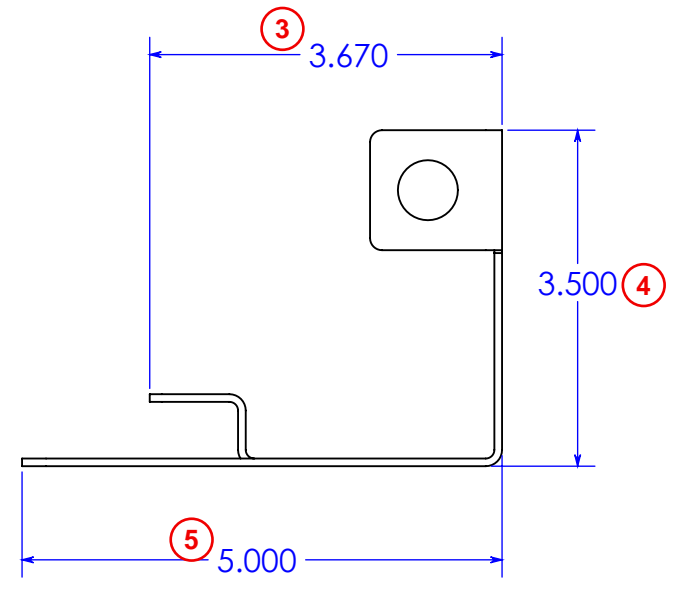
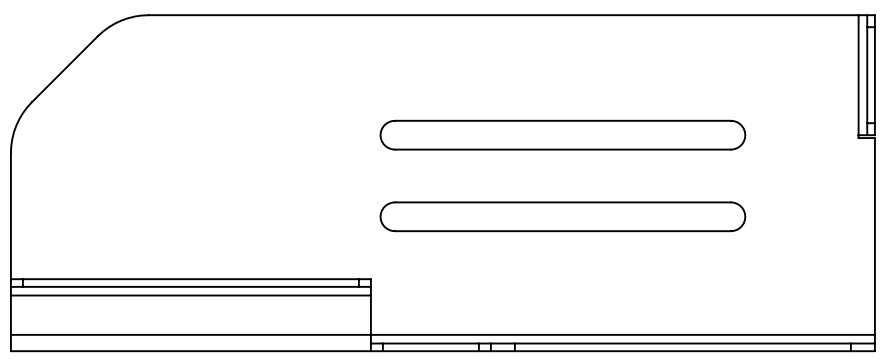
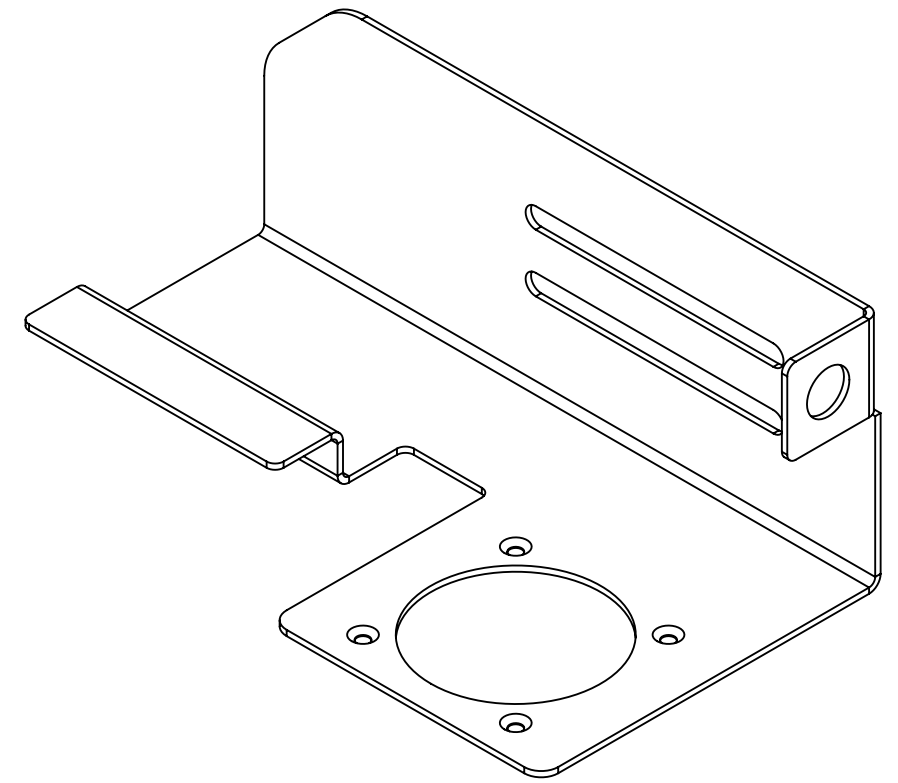
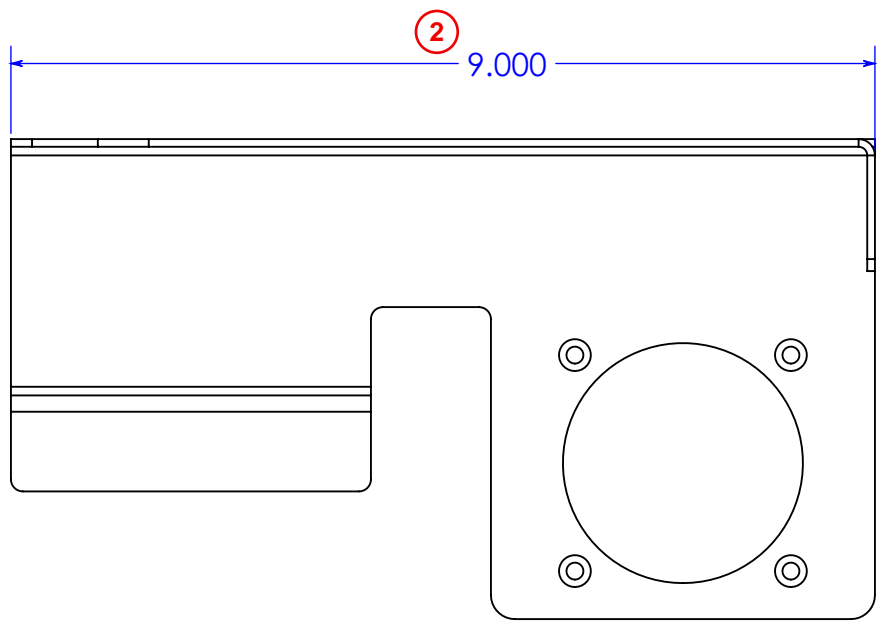

ITEM NO.	PART NUMBER	DESCRIPTION	QTY.
1	DIR Sample SM Part Rev C1	① 5052-H32 .080"	1

CREATED BY jim.worth

Saved in R:\Quality\1A Projects\Tiered Inspection\DIR Sample\

File Name DIR Sample SM Part Rev C1

8 7 6 5 4 3 2 1

D
C
B
A

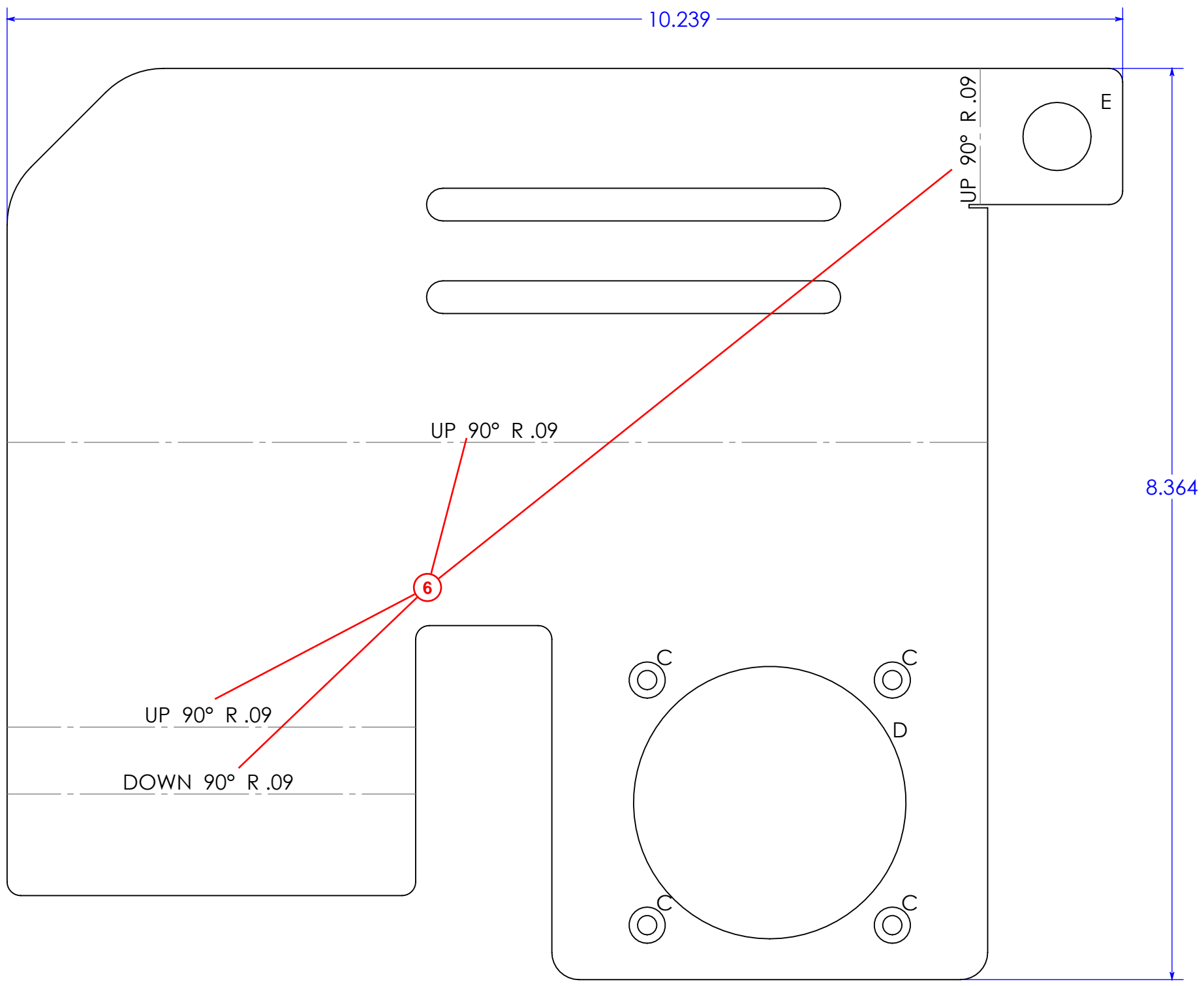

.080

D
C
B
A

ITEM NO.	PART NUMBER	DESCRIPTION	QTY.
1	DIR Sample SM Part Rev C1	5052-H32 .080"	1

TAG	SIZE	QUANTITY
C	ϕ .177 \downarrow .299	4
D	ϕ .332 X 100°	1
E	ϕ 2.500 THRU	1
	ϕ .625 THRU	1